

Features

- Quad/dual core 3rd Generation Intel® Core™ i7/i5/i3 Processor with Mobile Intel® QM77 Express Chipset
- Up to 16GB Dual Channel DDR3 SDRAM at 1600MHz
- Three Digital Display Interfaces (DDI) for DisplayPort /HDMI/DVI/SDVO
- Seven PCIe x1, one PCIe x16 (Gen3) for graphics (or general purpose x8/4/1)
- Two SATA 3 Gb/s, two SATA 6 Gb/s, Gigabit Ethernet, four USB 3.0, four USB 2.0

Specifications

Core System

CPU	3rd Generation Intel® Core™ i7/i5/i3, 22nm process, BGA type Intel® Core™ i7-3615QE 2.3GHz, 6MB L3 cache, 45W (4C) Intel® Core™ i7-3612QE 2.1GHz, 6MB L3 cache, 35W (4C) Intel® Core™ i7-3555LE 2.5GHz, 4MB L3 cache, 25W (2C) Intel® Core™ i7-3517UE 1.7GHz, 4MB L3 cache, 17W (2C) Intel® Core™ i5-3610ME 2.7GHz, 3MB L3 cache, 35W (2C) Intel® Core™ i3-3120ME 2.4GHz, 3MB L3 cache, 35W (2C) Intel® Core™ i3-3217UE 1.6GHz, 3MB L3 cache, 17W (2C) Intel® Celeron® 1020E 2.2 GHz (no Turbo) 35W (2C) Intel® Celeron® 1047UE 1.4 GHz (no Turbo) 17W (2C) Intel® Celeron® 927UE 1.5 GHz (no Turbo) 17W (1C)
Memory	Dual channel 1333/1600 MHz DDR3 non-ECC memory up to 16GB in dual stacked SODIMM socket
Chipset	Mobile Intel® QM77 Express Chipset
L3 Cache	6MB (i7-3615QE and i7-3612QE), 4MB (i7-3555LE and i7-3517UE), 3MB (i5-3610ME, i3-3120ME and i3-3217UE)
BIOS	AMI EFI with CMOS backup in 16 Mbit SPI flash
Hardware Monitor	Supply voltages and CPU temperature
Debug Interface	XDP SFF-26 extension for ICE debug
Watchdog Timer	Programmable timer range to generate RESET
Expansion Busses	PCI Express x16 (Gen3) bus for discrete graphics solution or general purpose PCI Express (2 x8 or 1 x8 with 2 x4) 8 PCI Express x1: Lanes 0/1/2/3/4/5/6 are free, lane 7 is occupied by GbE LPC bus, SMBus (system) , I ² C (user)

Video

Integrated in Processor	Intel® HD Graphics 4000 at 650~1200 MHz (depending on processor)
Integrated Video	DirectX 11, OpenGL 3.1, OpenCL 1.1
Feature Support	Intel® Clear Video HD Technology Advanced Scheduler 2.0, 1.0, XPDM support DirectX Video Acceleration (DXVA) support for full AVC/VC1/MPEG2 hardware decode
VGA Interface	Analog VGA support with 300 MHz DAC Analog monitor support up to QXGA (2048 x 1536) and VGA hot plug
LVDS Interface	Dual channel 18/24-bit LVDS
Digital Display Interface	Three DDI ports supporting HDMI/DVI/DisplayPort or SDVO

Audio

Chipset	Integrated in Mobile Intel® QM77 PCH
Audio Codec	On Express-BASE6 carrier (ALC886)

Ethernet

Chipset	Intel® Gigabit Ethernet PHY WG82579LM
Interface	10/100/1000 Mbps Ethernet

I/O Interfaces

Chipset	Integrated in Mobile Intel® QM77 PCH
USB	4 ports USB 3.0 (USB3~3) and 4 ports USB 2.0 (USB4~7)
SATA	Supports two SATA ports at 6 Gb/s and two ports at 3 Gb/s with support for RAID 0,1,5,10

Super I/O

Connected to LPC bus on carrier if needed

TPM (optional)

Chipset	Infineon SLB9635TT1.2
Type	TPM 1.2

Power

Input Power	8.5~20V only (AT), 8.5~20V and 5Vsb (ATX)
Power States	Supports S0, S1, S3, S4, S5
Smart Battery Support	Yes
Power Consumption	40W with i7-3612QE and 4GB memory typical

Mechanical and Environmental

Form Factor	PICMG COM.0: Rev 2.1 Type 6
Dimension	Basic size: 125 mm x 95 mm
Operating Temperature	Standard: 0°C to +60°C
Storage Temperature	-20°C to +80°C
Humidity	90% at +60°C
Shock	15G peak-to-peak, 11ms duration, non-operating
Vibration	Non-operating: 1.88Grms, 5-500Hz, each axis Operating: 0.5Grms, 5-500Hz, each axis
Compatibility	COM Express Type 6, Basic form factor 125mm x 95mm
Certification	CE, FCC, HALT

Operating Systems

Standard Support	Windows 7, Linux
Extended Support (BSP)	Embedded XP support package, Linux BSP, VxWorks 6.x, AIDI Library for Windows and Linux

Functional Diagram

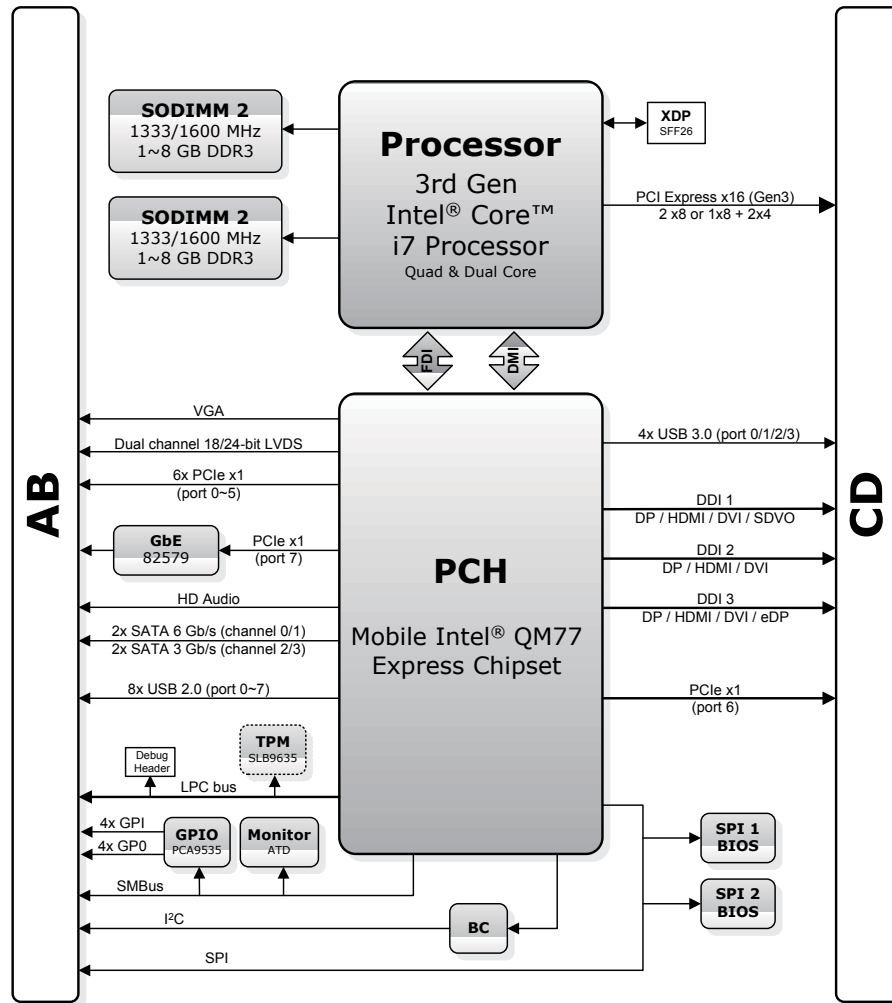

Ordering Information

Modules

Model Number	Description/Configuration
Express-IB-i3-3120ME	COM Express® Basic Size Type 6 Module with Intel® Core™ i3-3120ME SV at 2.4 GHz
Express-IB-i3-3217UE	COM Express® Basic Size Type 6 Module with Intel® Core™ i3-3217UE ULV at 1.6 GHz
Express-IB-i5-3610ME	COM Express® Basic Size Type 6 Module with Intel® Core™ i5-3610ME SV 2.7 GHz
Express-IB-i7-3517UE	COM Express® Basic Size Type 6 Module with Intel® Core™ i7-3517UE ULV at 1.7 GHz
Express-IB-i7-3555LE	COM Express® Basic Size Type 6 Module with Intel® Core™ i7-3555LE LV at 2.5 GHz
Express-IB-i7-3612QE	COM Express® Basic Size Type 6 Module with Intel® Core™ i7-3612QE SV at 2.1 GHz
Express-IB-i7-3615QE	COM Express® Basic Size Type 6 Module with Intel® Core™ i7-3615QE SV at 2.3 GHz
Express-IB-1020E	COM Express® Basic Size Type 6 Module with Intel® Celeron® 1020E at 2.2GHz
Express-IB-1047UE	COM Express® Basic Size Type 6 Module with Intel® Celeron® 1047UE 1.4 GHz
Express-IB-927UE	COM Express® Basic Size Type 6 Module with Intel® Celeron® 927UE 1.5 GHz

Accessories

Model Number	Description/Configuration
Heat Spreaders	
HTS-IB-B	Heatspreader for Express-IB with threaded standoffs
HTS-IB-BT	Heatspreader for Express-IB with through hole for top mounting
Passive Heatsinks	
THSH-IB-B	High profile heatsink for Express-IB with threaded stand-offs
THS-IB-BL	Low profile hearsink for Express-IB for bottom mounting
Active Heatsink	
THSF-IB-B	High performance heatsink with Fan for Express-IB 2C with threaded standoffs

Note: All specifications are subject to change without further notice.